

**HYE125MHU**      C O M P R E S S O R

---

**TECHNICAL SPECIFICATION**

(220-240V~50Hz)

CHANGHONG HUAYI COMPRESSOR CO., LTD.

**2020. 10**

## INDEX

	Page
1、 Compressor Type.....	2
2、 Performance Data.....	2
3、 Running Condition.....	2
4、 Compressor Mechanical Information.....	3
5、 Compressor Shape.....	3
6、 Wiring Diagram.....	4
7、 Fixing of mounting bracket and cabinet base.....	4
8、 Assembly of starter and protector.....	5
9、 Delivery State.....	6
10、 Package、 Storage and Transportation.....	6
11、 Technical Items.....	7

## 1. Compressor Type

Compressor model	HYE125MHU
Rated voltage/frequency	220-240V~50Hz
Refrigerant	R600a
Application	Low Back Pressure (LBP)
Cooling method	Static Cooling
Control device	Capillary tube
Motor type	RSIR
Capacitor	-

## 2. Performance Data

Displ.(cm <sup>3</sup> )	Capacity(W) ≥95%	Inp.Pow.(W) ≤115%	Rated Current(A) ≤110%	COP (W/W) ≥95%
12.5	215	172	1.30	1.25

Testing condition:

Test conditions	LBP
	ASHRAE
Evaporating Temp.	-23.3℃
Ambient Temp.	32.2℃
Condensing Temp.	54.4℃
Suction Temp.	32.2℃
Subcooling Temp.	32.2℃

## 3. Running Condition

Ambient temp.	10~43℃
Evaporating temp.	-35~-15℃
Voltage range	187~254V
Max. condensing temp.	65℃
Max. winding temp.	130℃
Max. shell temp.	95℃
Max. discharge temp.	125℃

#### 4. Compressor Mechanical Information

Oil type	mineral
Oil charged	180ml
Diameter of suction tube (I.D.)	$\Phi 6.1_{0}^{+0.1}$ mm
Diameter of discharge tube(I.D.)	$\Phi 4.9_{0}^{+0.1}$ mm
Diameter of process tube (I.D.)	$\Phi 6.1_{0}^{+0.1}$ mm
Material of suction tube, process tube and discharge tube	copper tube
Compressor noise	$\leq 42\text{dB(A)}$
Vibration	$\leq 0.8\text{m/s}^2$

#### 5. Compressor Shape (connections on suction and process can not be inverted)

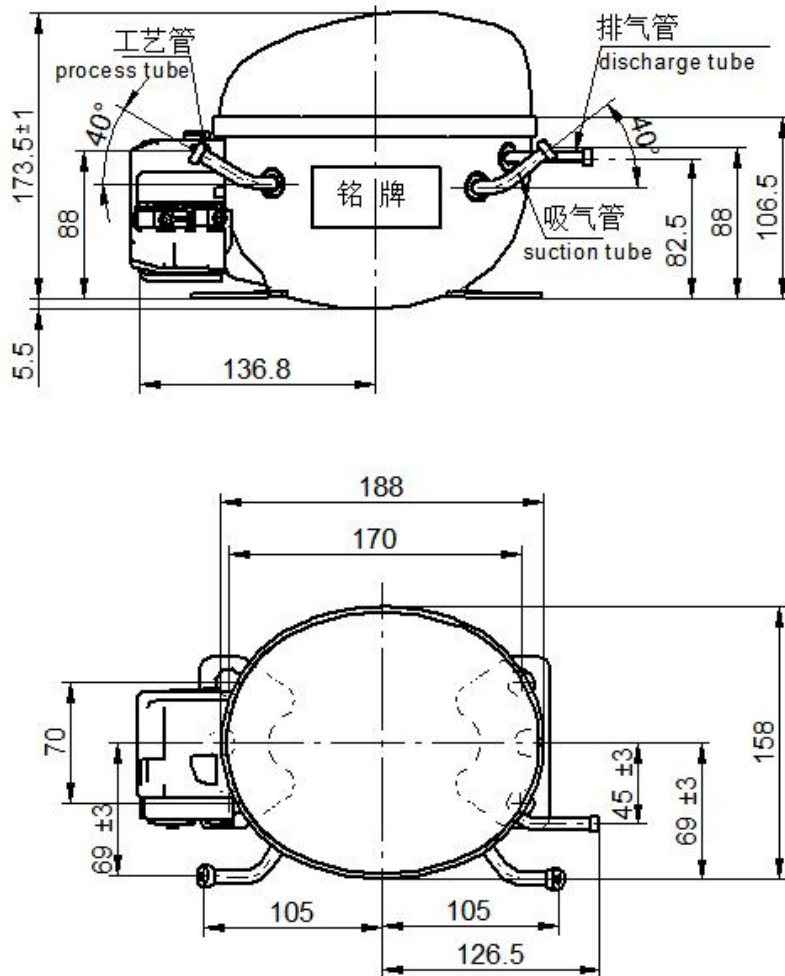

## 6. Wiring Diagram

RSIR:

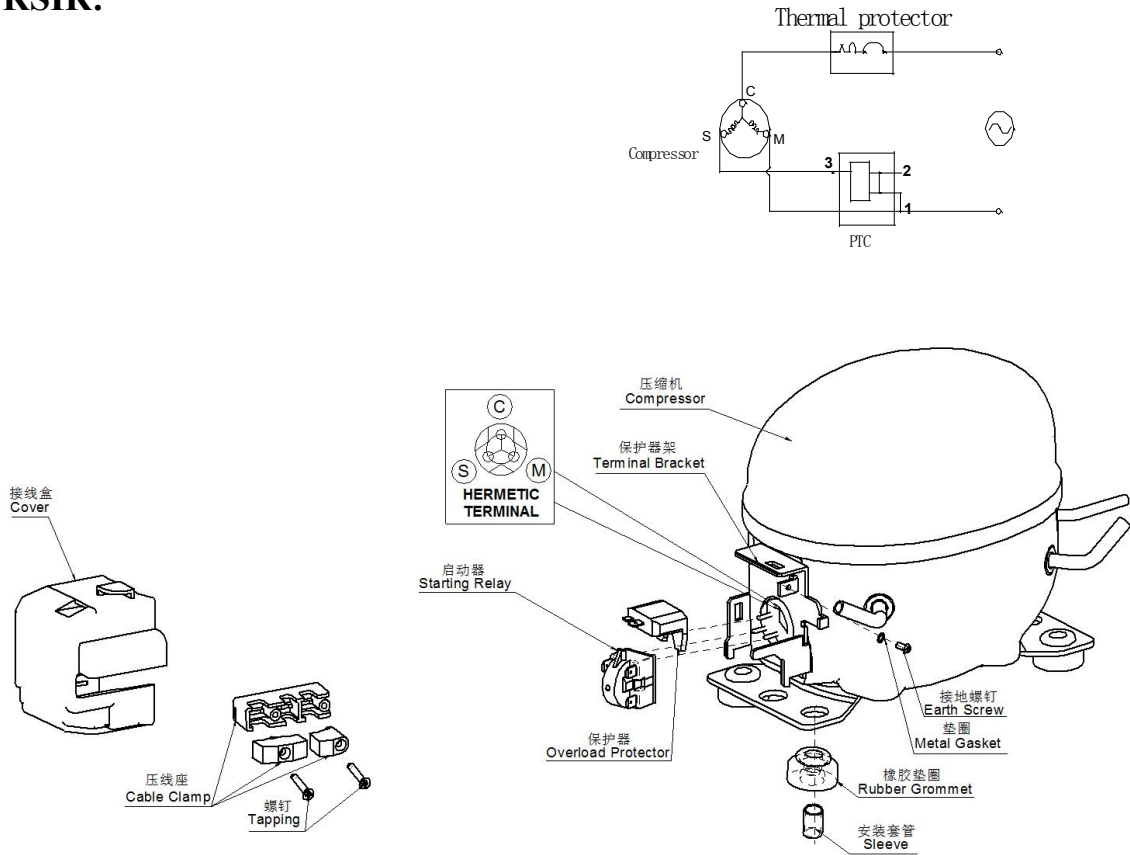

Note: Each of the starting relay、 the thermal protector、 the terminal cover and the screw assembly is separately provided by our company.

## 7. Fixing Of Mounting Bracket And Cabinet Base

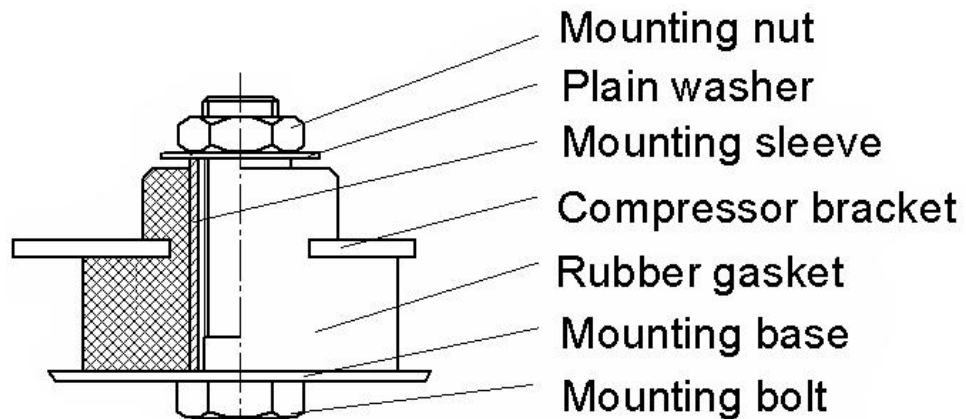

## 8. Assembly of starter and protector

### 8.1 Starting relay

**Model:** QP2-12/B3

Type: Starting relay

max current: 8A

max working voltage: 350 V

Flammability: Anti-flammability

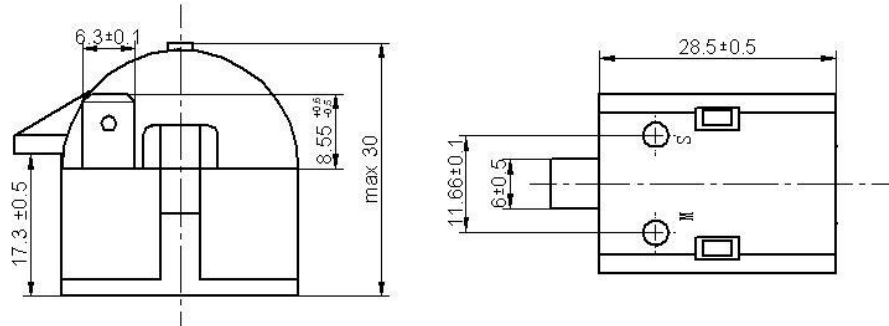

### 8.2 Thermal protector

**Model:** DRB23P61A1/ BT62-125

model		DRB23P61A1	BT62-125
Thermal Protector	Max. T.C Amp.(25°C) A	6.2	6.2
	Trip time S	6~14	6~14
	Reset time S	50~150	50~150
	Open temp. ±5°C	125	125
	Close temp. ±9°C	61	61
	Min. T.C Amp.(71°C) A	1.50~1.89	1.50~1.89

Flammability: Anti-flammability

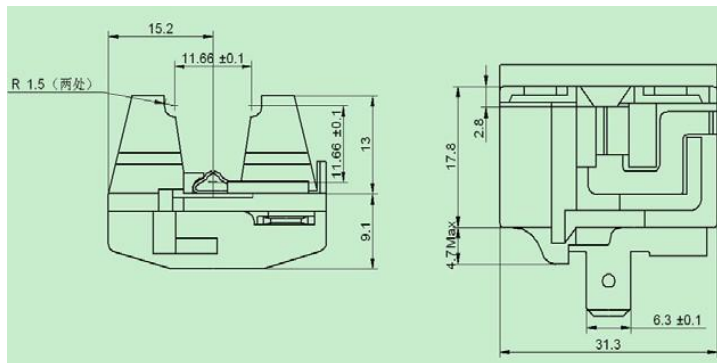

## 9. Delivery State

No.	Name	Model	Quantity	CODE
1.	Compressor	HYE125MHU	1 pcs	
2.	<i>MOUNTING ACCESSORIES</i>			
2.1.	<b>Rubber Gasket</b>		4 pcs	E. 24. 12. 201
2.2.	Plain washer		4 pcs	CTE983-2
2.3.	Mounting sleeve		4 pcs	CTE943-2 (16)
2.4.	Mounting blot	M6X30	4 pcs	GB5781-86
2.5.	Mounting nut	M6	4 pcs	GB6170-86
3.	<i>ELECTRICAL ACCESSORIES</i>			
3.1.	Starting relay	QP2-12/B3	1 pcs	
3.2.	Thermal protector	DRB23P61A1/ BT62-125	1 pcs	
3.3.	Terminal Cover		1 pcs	E.24.01.59
3.4.	Screw Assembly		1 pcs	E.14.24.201
3.5.	Running Capacitor	5	1 pcs	

Notes: 1.All electrical parts and equipment assembly are supplied separately, not installed on the compressor.

2. All electrical parts and equipment assembly according to Delivery states are all provided by our company.

## 10. Package、Storage and Transportation

Package type	unreusable
Quantity	72pcs/box
Transportation	By truck or train
Storage	Max. 2 layers
Volume m <sup>3</sup>	0.88
Dimension: length×width×height (mm)	1120×820×960
Main components	Wooden supporter、foam divider、plastic sheet、cardboard cover、wrapping
Movement	Keep the compressor in normal or vertical position (a short time before compressor installed in the refrigerator).
Trans. test requirement	No allowable compressor's damage and performance loss.

## 11. Technical Items

1. After pulling off rubber plugs from the compressor tubes, please connect the compressor to the refrigeration system within 5 minutes. It is advisable to take off the first plug from process tube. No dust or humidity in the air is permitted to enter the compressor.
2. Earth connection should be fixed permanently and reliably.
3. The compressor must be mounted horizontally without tilting an angle more than 5° .
4. Maximum operating ambient temperature is at 43°C .
5. When the compressor starts, balance pressure inside refrigeration system must be less than 0.3Mpa (Absolute).
6. The compressor must not be restarted unless at an interval of more than 5 minutes.
7. Please keep the compressor always vertically and never upset it during transportation while avoiding any vibration and shock.
8. Please store the compressor in a dry and ventilated place and keep it away from any humidity.
9. Please follow the transportation warning marks on the package for layer limitation. Do not roll the whole packages when loading or unloading.
10. Storage expiry is 6 months from the date of production. If it expired, please check the nitrogen pressure inside compressor and recharge it when it is necessary.